

Master's thesis

Topic: Application of genetically encoded tension sensor modules to pancreatic cancer organoids

Project description:

Mechanical forces play a crucial role in development and disease. For a better understanding of how forces are transmitted within sub-cellular structures, genetically encoded tension sensors can be applied to measure forces across certain proteins. In this project, tensions across ECM-cell- and cell-cell-interactions within pancreatic ductal adenocarcinoma (PDAC) organoids are focused. For that, the tension sensor modules (TSMs) that are based on FRET, are genetically integrated into the proteins vinculin and alpha-catenin. By using fluorescence lifetime imaging microscopy (FLIM), the localization and dynamics of molecular tension upon the specific proteins is identified during different developmental stages of the pancreatic cancer organoid model. Together, this data can give evidence for possible cancer treatments targeting the transmission of forces needed for the development of cancerous tissue.

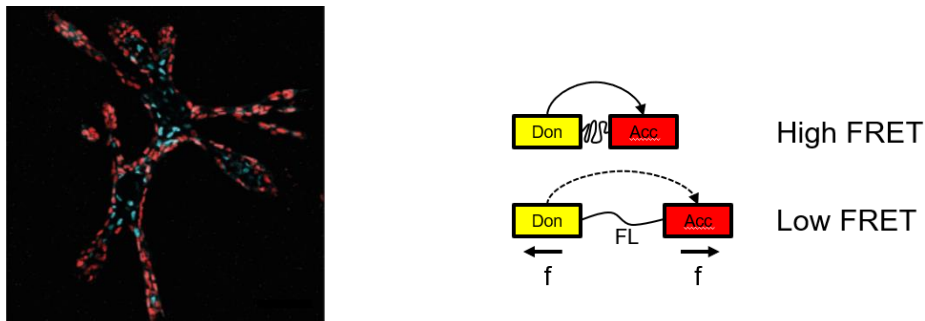

Figure 1 PDAC cells cultured in collagen give rise to branched organoids with a central lumen and tubular-like buds. **Left:** 3D reconstruction of a Day 13 PDAC organoid staining in collagen. **Right:** General design of the tension sensor module. The tension sensor module (TSM) consists of two fluorophores, a donor (Ypet) and an acceptor (mCherry), separated by a peptide linker sequence. When force across the TSM extends the elastic linker, FRET efficiency decreases (f, force).

Your Profile:

- Surpassing grades in your master's program in biology, (bio)chemistry, biotechnology, physics, or related scientific program
- Genuine interest in the powerful applications of cancer organoids and FLIM-FRET imaging
- Previous experience with fluorescence microscopy
- Advanced programming skills (Python, matlab,...) for image data processing
- The ability to be self-motivated and to work independently within an interdisciplinary team of biotechnologists and physicist
- English language and organizational skills

Starting date: 02/22 **Duration:** 6 months / 12 months for physicists

Contact person: M.Sc. Sophie Kurzbach, sophie.kurzbach@tum.de

Website: <https://www.bauschlab.org/>